

Pneumatic Dispenser-Gun Operating Instructions for Twin 400 Cartridges (1:1)

Getting started

- ◆ Connect gun to air compressor.
- ◆ **Maximum operational pressure: 5 bar.**
- ◆ Operate system only with a coalescing filter/lubricator installed at air connection point.
- ◆ Install 1/4" (internal screw thread) BSP to pressure regulator; we recommend to employ free-turning in-line quick couplings.
- ◆ Use flexible tube, diameter 6 mm.

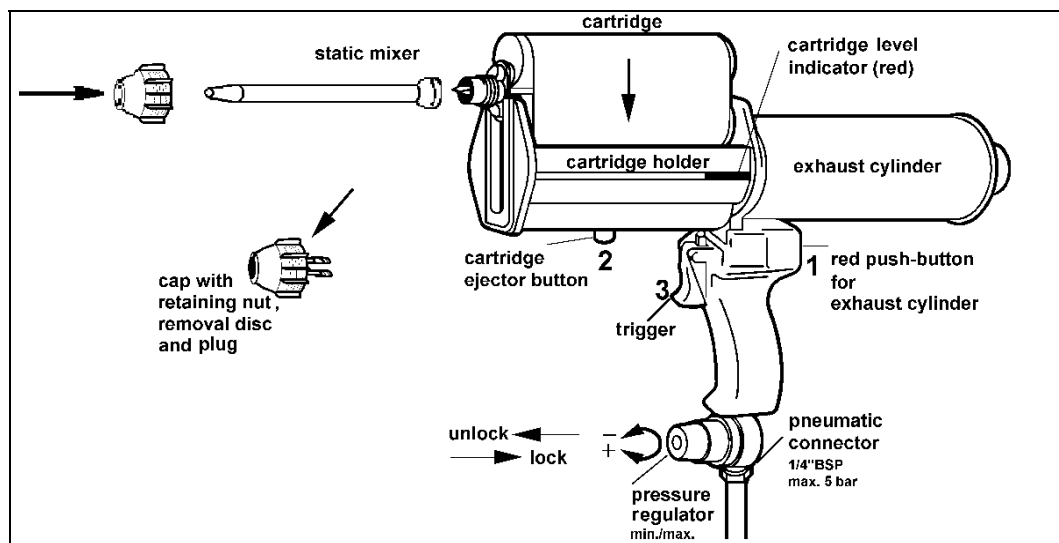

Measurements (W x H x L): 95 x 300 x 480 mm, Weight 2 110 g (without cartridge)

Operation

- ◆ Unscrew **complete** cap from cartridge. Do not take off removal disc separately, since cap pulls plug from cartridge with help of removal disc.
- ◆ Only now pull removal disc and remove green plug from cap.
- ◆ Put static mixer on dispensing end of cartridge.
- ◆ Slide cap over static mixer and screw tightly to dispensing end of cartridge.
- ◆ Put cartridge into cartridge holder (see above picture) and push to the stop.

Attention

Cartridge must **lock** into cartridge holder. If not locked in properly, the trigger **(3)** cannot be operated and the exhaust cylinder will not move!

- ◆ Select desired dispensing pressure at pressure regulator (pull knob to unlock).
- ◆ Push the trigger **(3)** to start dispensing the adhesive mixture.
- ◆ The pressure regulator allows easy readjustments of the quantity to be dispensed.

Advice

Should the dispense rate be too low even at maximum pressure, the tip of the mixer may be shortened (by 30 mm at the most), increasing the cross-section.

Removal of cartridge

- ◆ Release trigger.
- ◆ Keep red push-button (1) pressed until exhaust cylinder has returned to rear stop (watch red level indicator).
- ◆ Press ejector button (2) to release and push cartridge upwards.
- ◆ Pull cartridge all the way up to remove from cartridge holder.

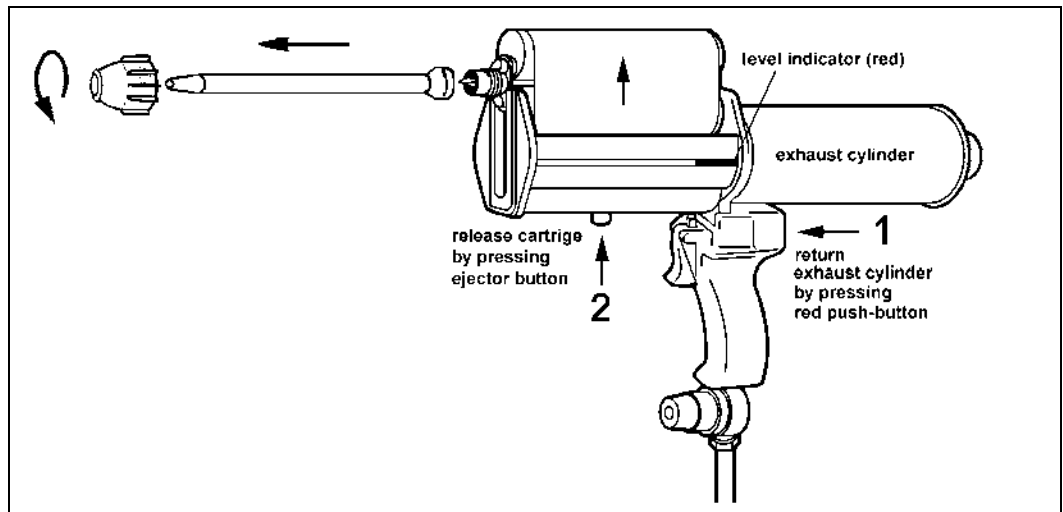

Maintenance

- ◆ Make sure filter/lubricator unit functions properly.
- ◆ Remove uncured adhesive residues from the dispenser-gun by wiping off with our cleaning agent Agomet® Metal Cleaning Agent

Cautionary information

- ◆ Always relieve pressure from dispenser-gun before longer breaks.
- ◆ The dispenser-gun's **maximum operational pressure** is limited to **5 bar**.
- ◆ Observe all safety advices for the adhesive-filled cartridges.

All recommendations for the use of our products, whether given by us in writing, verbally, or to be implied from the results of tests carried out by us, are based on the current state of our knowledge. Notwithstanding any such recommendations the Buyer shall remain responsible for satisfying himself that the products as supplied by us are suitable for his intended process or purpose. Since we cannot control the application, use or processing of the products, we cannot accept responsibility therefor. The Buyer shall ensure that the intended use of the products will not infringe any third party's intellectual property rights. We warrant that our products are free from defects in accordance with and subject to our general conditions of supply.

Vantico
Adhesives and Tooling
Duxford, Cambridge
England
CB2 4QA
Tel: +44(0)1223 832121
Fax: +44(0)1223 493322
www.vantico.com

© Vantico, 2002
® Agomet is a registered trademark of Vantico AG, Basel, Switzerland